

# RAPIDO 53XS

RAPIDO 53XS  
Information Pack

- All carbon
- Spreader-less pre-preg carbon mast and V boom made in house





# The new standard

- The “Xtra Space” of the Rapido 53XS is for sailors requiring three cabins without unduly compromising performance.
- Morrelli & Melvin have achieved this by retaining the same efficient shape of the Rapido 50’s hull at the waterline level while above, she flares out to support an expansive deck at the cost of just 800kgs to the trimaran’s overall weight.

## OTHER FEATURES

- Two C curve pre-preg carbon dagger boards (foils), one in each float hull.
- Foils replace central dagger board resulting in more space in the saloon with 360 degree views.
- Twin fixed pre-preg carbon rudders one on each float hull (replacing central rudder) that extend to the lowest point of the main hull to facilitate access to shallow water.
- Three cabins and two heads with additional sleeping arrangements.
- The R50XS is non folding.

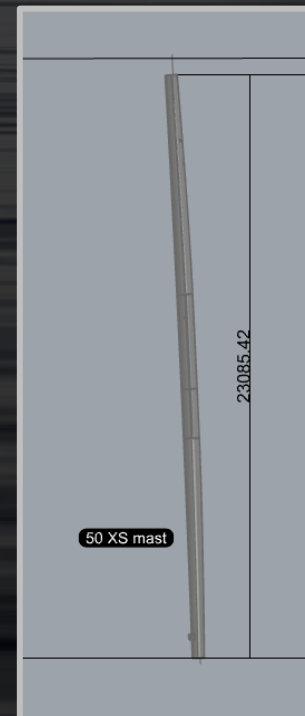
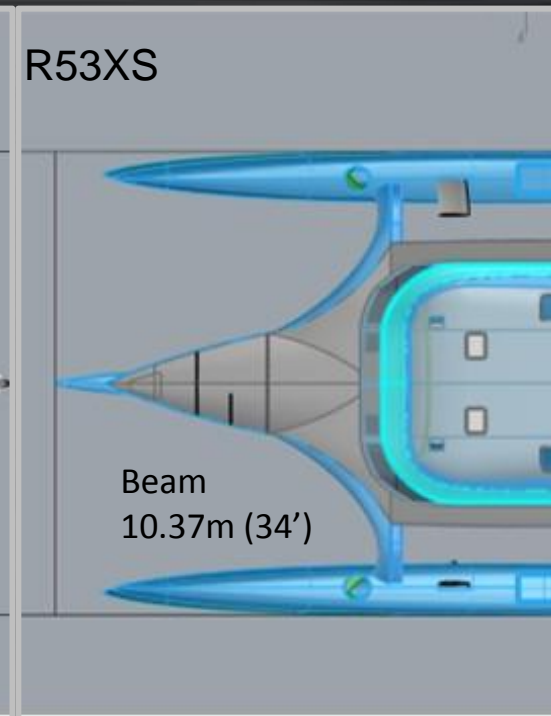
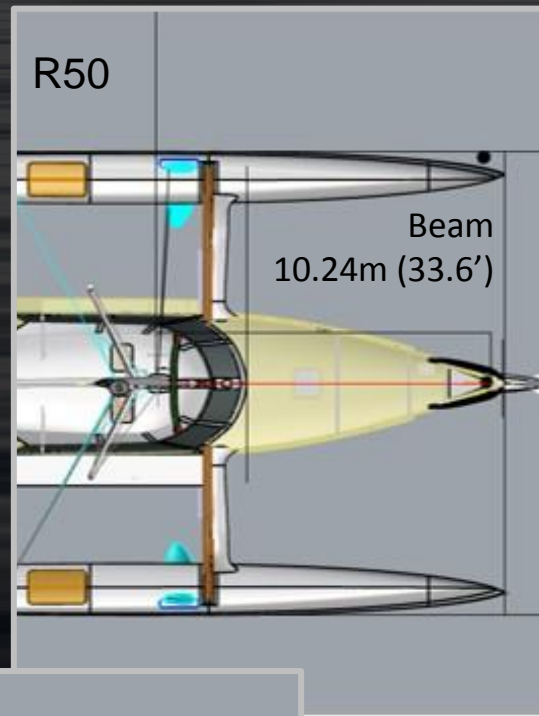
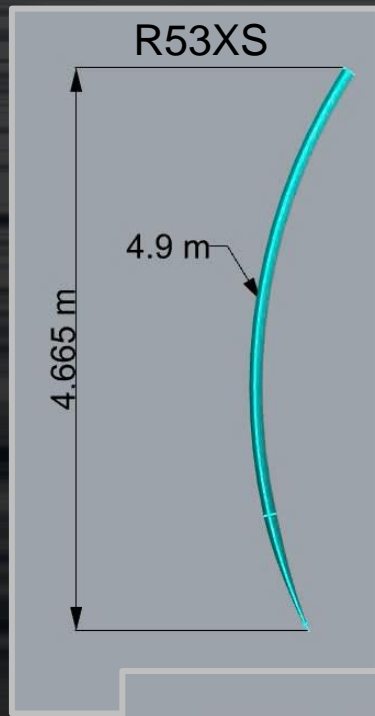
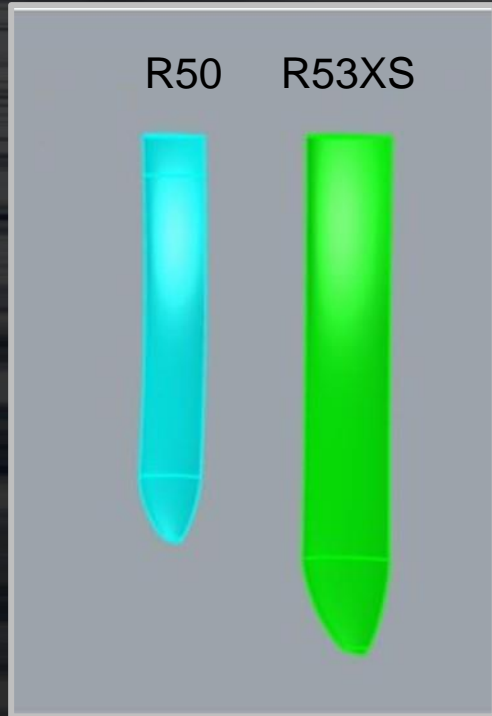

### FOILS

The foils on the 53XS are significantly bigger than those on the 50 Classic as the XS does not have a centre daggerboard.

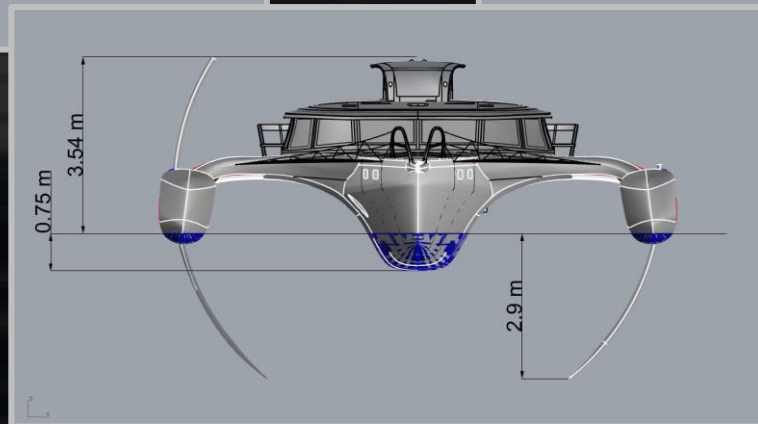

### BEAM

R50 – 10.24m (33.6')  
R53XS: 10.37m (34')

### MAST

R53XS: 23.09m (75.8')



# "My choice is to have a boat that would..."

## La strana barca di Mr. Fumagalli

L'ex patron di Candy si è fatto costruire in Vietnam il super trimarano giramondo Rapido 53 XS e ce ne svela tutti i segreti

È in costruzione un nuovo multiscifo a vela firmato Rapido Trimarans. Il cantiere, con sede in Vietnam, è ormai un punto di riferimento per i trimarani: l'esperienza e la passione del fondatore Paul Coch, che dal 1986 si occupa di costruire multiscifi oceanici, sono diventate il fulcro del costruttore. Il futuro di Rapido Trimarans si chiama Rapido 53 XS, sigla che significa eXtra Space. Chi è l'armatore?

Aldo Fumagalli, ingegnere italiano ex proprietario del marchio di elettrodomestici Candy. Fumagalli ha una passione smodata per la vela e le traversate, ed è già stato armatore del Neel 47 Minimolo con cui ha partecipato a tantissime regate-avventura, tra le quali la ARC Plus (che ha vinto) e ha navigato tantissimo oltreoceano. Il suo collaboratore inseparabile è Patrick Phelipon (una Whitbread assieme Tabarly, tante barche progettate alle spalle, una vita in Italia tra i "favoriti" di Cino Ricci).

"Il mio amore nasce quasi dal nulla quando avevo 40 anni, perché fino ad allora le mie esperienze in barca non andavano oltre la classica vacanza estiva di due o tre settimane a bordo di un charter con amici", ci racconta l'ex proprietario del marchio Candy.

### SPAZI XXL E VELOCITÀ

La sua nuova imbarcazione è pensata per velisti che vogliono ampi spazi a bordo, senza però rinunciare alle performance. "La mia scelta è quella di avere una barca che in una decina di giorni mi porti ai Caraibi", ci confessa Fumagalli, "con un'imbarcazione lenta di si metterebbero circa tre settimane e, a quel punto, le vacanze sarebbero già finite".

Sviluppato dallo studio Morrelli & Melvin, il 53 XS parte dalla già ottima base del 50 piedi presentato nel 2020 che, per l'occasione, viene ampliata senza essere stravolta.

Aldo continua a raccontarci: "Ho scelto Rapido perché fa barche fuori dagli schemi, con spazi e dimensioni non standard. Insieme al mio skipper Patrick Phelipon abbiamo pensato ad una barca adatta anche alla navigazione in solitario; per questo la scelta è ricaduta su una misura che non andasse oltre i 50 piedi, per non avere troppi problemi a gestire le vele.

Alla fine, però, ci siamo fatti prendere la mano: l'albero è quello in carbonio di un 18 metri e la superficie velica è come quella di un IMOCA 60!".



**I NUMERI DEL RAPIDO 53 XS**  
Lunghezza f.t.: 16,1 m  
Larghezza max: 10,36 m  
Pescaggio: da 0,67 m a 3,94 m  
Dislocamento: 9250 kg  
Sup. randa 117 mq  
Sup. asimmetrico 230 mq  
Sup. raacher 150 mq  
Sup. focca 72 mq  
Sup. Staysail 25 mq  
<http://rapido.trimarans.com/rapido-53xs>

La totale assenza di deriva e entrate è rimpiazzata sul nuovo Rapido 53 XS da due pinne C-foil in carbonio poste sugli scafi esterni (non immagino la ben visibile qualità di equipaggio): questo permette una navigazione ancora anche su bassi fondali, poiché a foil retratti, il pescaggio è di appena 67 cm. Ma in navigazione queste due "ali" si possono allungare fino a quasi 4 metri di profondità.



Aldo Fumagalli (64 anni) a bordo della sua vecchia barca, il Neel 47 Minimolo con cui ha vinto la ARC Plus.

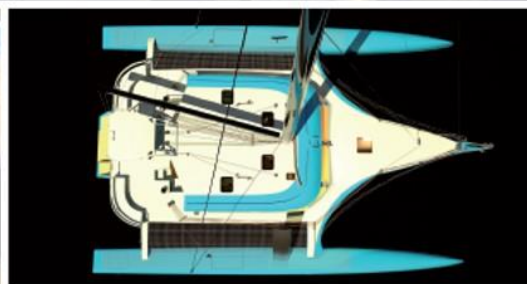

Se si guarda il Rapido 53 XS dall'alto, si vede subito come il corpo centrale sia stato studiato per offrire spazi XXL. Ma le prestazioni a vela non mancheranno di certo.



Il randoning dall'interno dello scafo centrale del nuovo Rapido 53 XS che ha preso vita in Vietnam per Aldo Fumagalli. La comodità è stata una richiesta dell'armatore.

Niente paura per sicurezza e comfort in navigazione, perché queste "ali" si possono

portare, lasciando così inalterata a 10,36 metri la larghezza della barca: un dato da tenere in

mai pronta. Fumagalli partirà dal Vietnam "e bo ippezzeato di essere in Oman verso la metà di

# take me to the Caribbean in about 10 days."

le a poppa. All'interno, invece, oltre al citato salone sono presenti tre cabine matrimoniali e due bagni, oltre alla cucina a C. Il Rapido 53 XS, rispetto al "donatore" 50 piedi, ha un solo svantaggio, ovvero gli scafi esterni sono fissi e non possono scorrere l'uno verso l'altro per ridurre l'ingombro in

l'operazione, per tenere la barca in configurazione serena sono necessarie particolari condizioni di mare e vento, anche in porto". Con un albero così alto, in effetti uno scafo sureto diventerebbe instabile da fermo, col rischio che una raffica di vento o un'ondata più alta del previsto possano capovolgere. Aldo Fumagalli ci dice che la sua barca è or-

fo di Aden bisogna proseguire in convoglio: basta scegliere quello giusto e navigheremo indenni fino al Canale di Suez". Federico Lanfranchi

Mr Aldo Fumagalli is the owner of Rapido 53XS Hull #01.

In this article in Vela magazine, Aldo explains why the Rapido 53XS is such a good fit for him.

[Click here to read the original article in English](#)

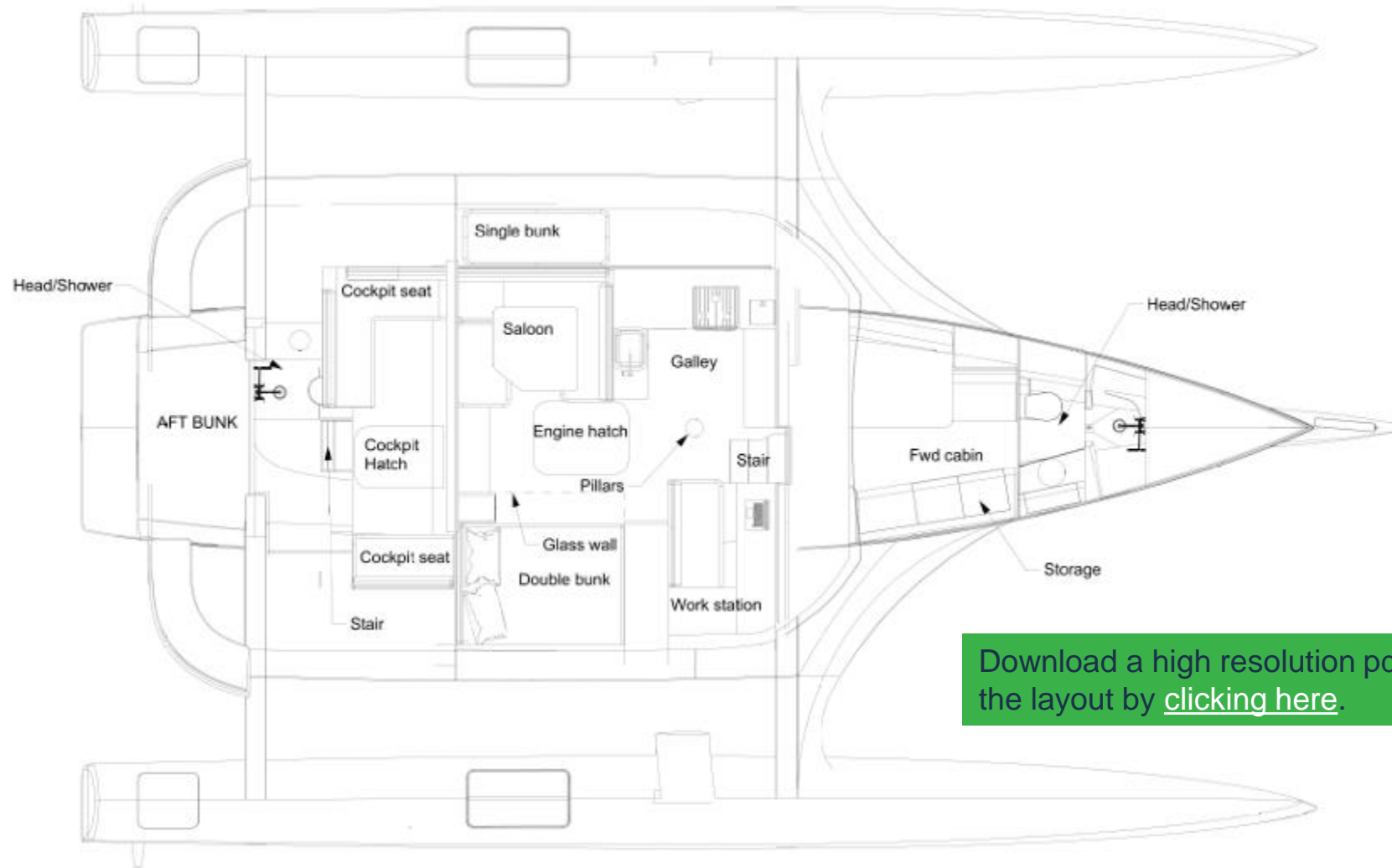

Download a high resolution pdf file of the layout by [clicking here](#).

## Headroom / Ceiling Height

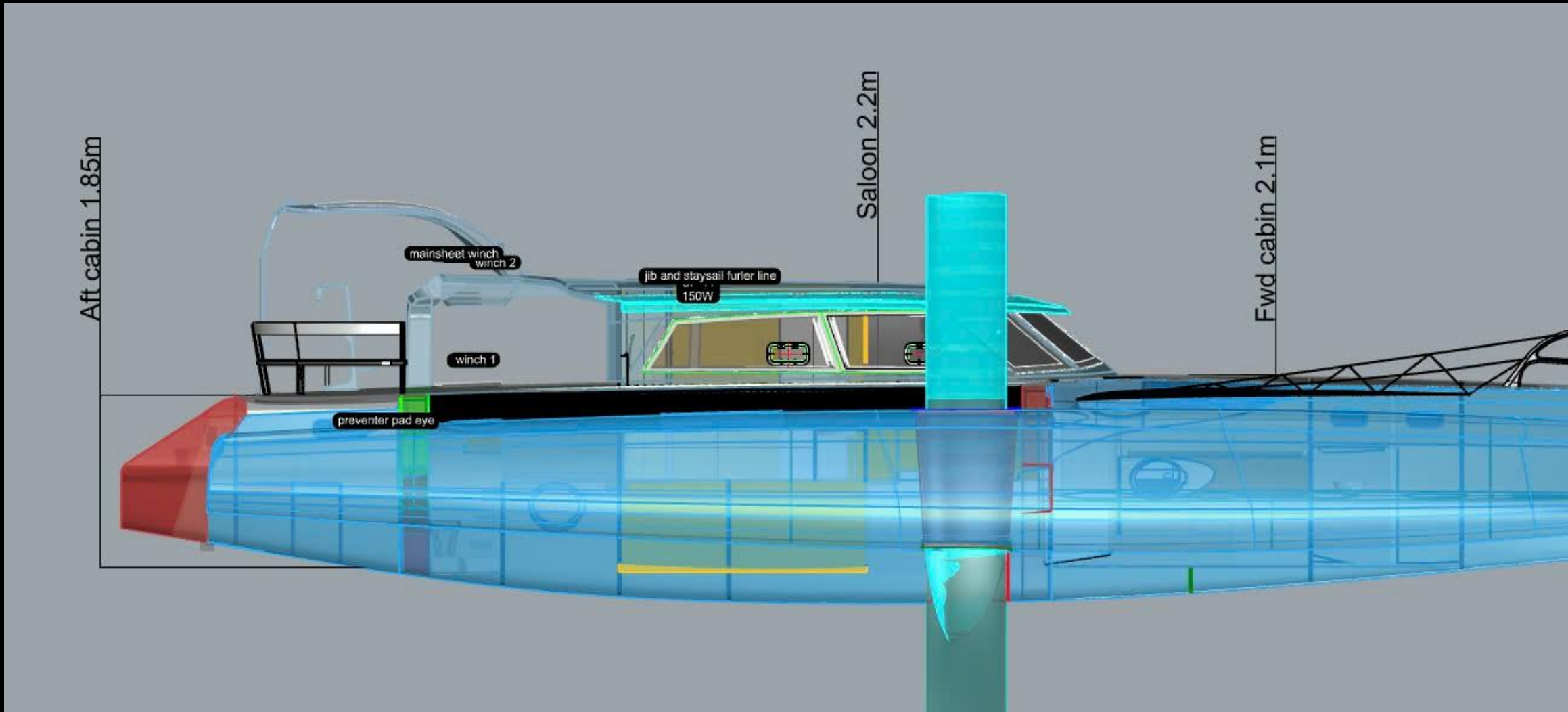

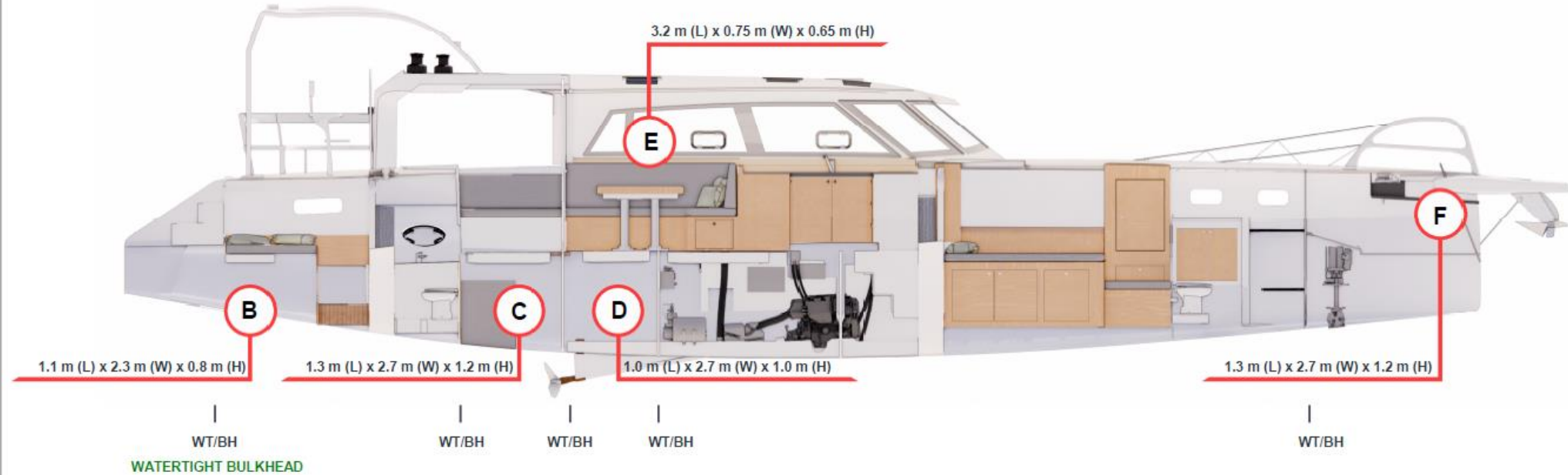

Download a high resolution pdf file of the layout by [clicking here](#).

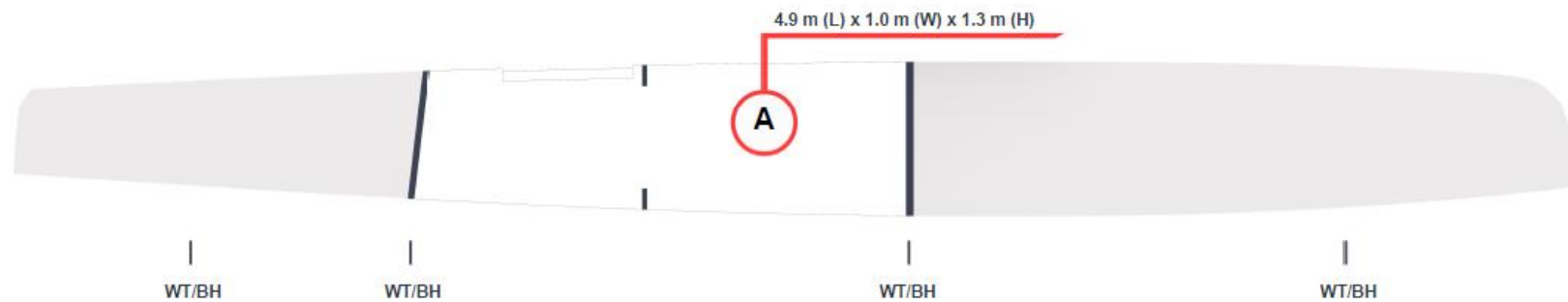

# RAPIDO 53XS





# RAPIDO 53XS

Saloon | Galley | Nav Station |  
Stbd Cabin







Same forward cabin and head as in Standard Rapido 50.



Same aft cabin and head as in Standard Rapido 50.

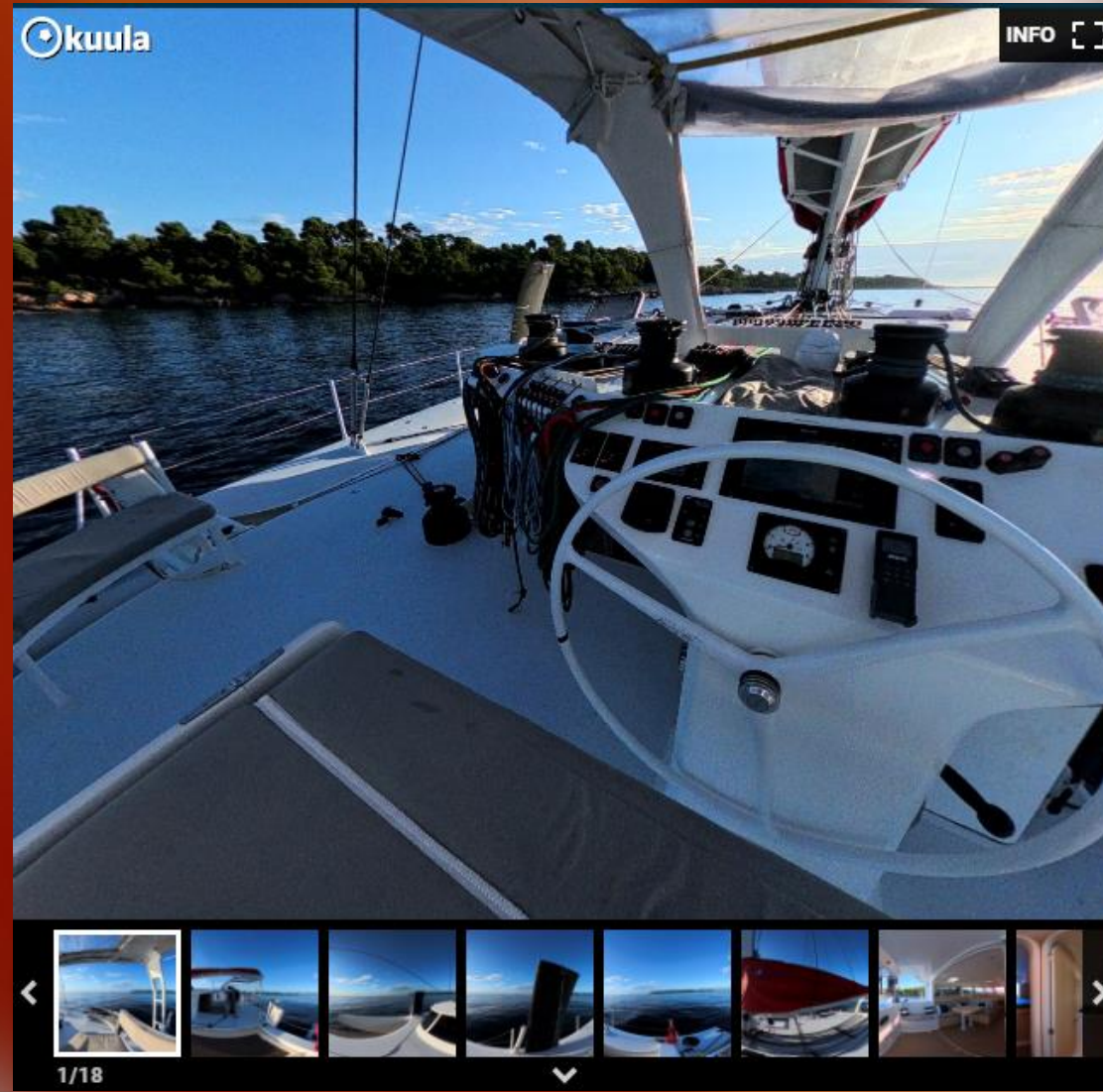

To take a virtual tour of the Rapido 53XS, [click here](#).

# RAPIDO 53XS

Engine compartment is “massive”



### FLOATS

Storage volume  
(at greatest dimension):

- (L) 4.6m
- (W) 1.1m
- (H) 1.5m



# RAPIDO 53XS

## Storage space: Sub cockpit & Locker

### BENEATH COCKPIT FLOOR

Storage volume  
(at greatest dimension):

- (L) 1.3m
- (W) 2.7m
- (H) 1.2m

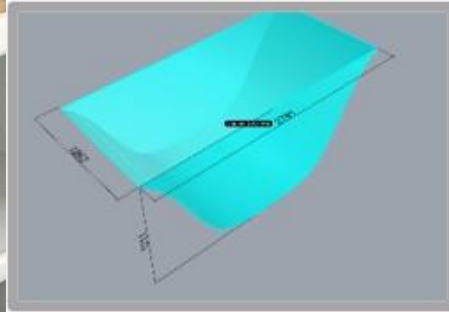

### COCKPIT LOCKERS

Indicative storage volume (based on R50):

- (L) 1.7m
- (W) 0.44m
- (H) 0.50m



Cockpit lockers offer  
dedicated wet  
weather and shoe  
space

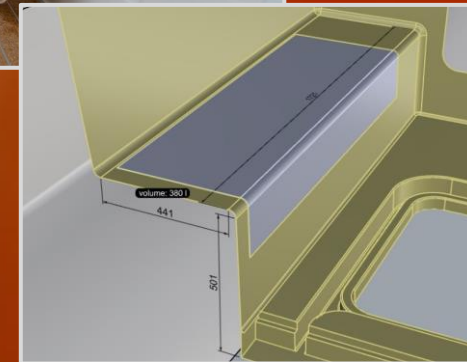

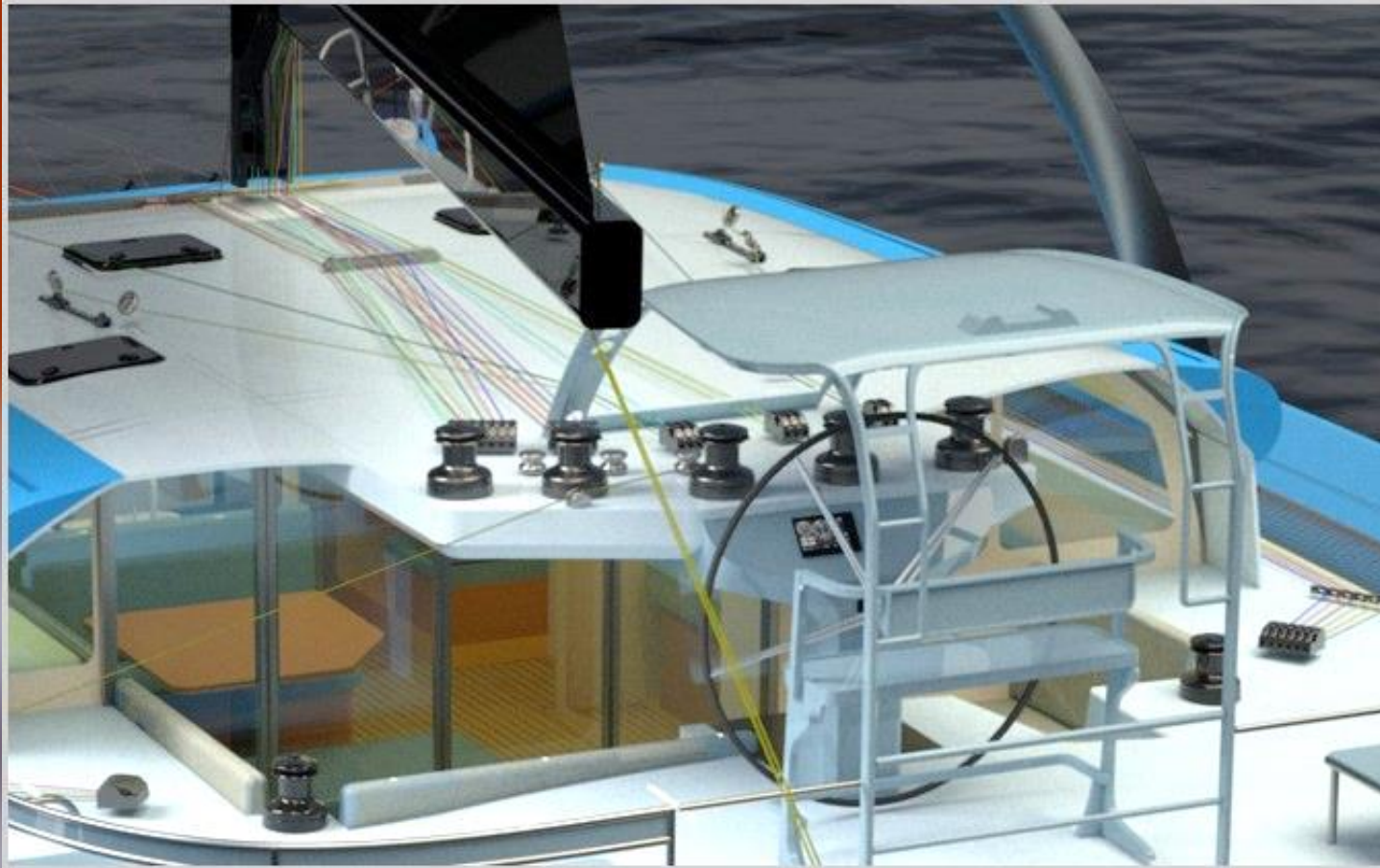

- The helm position offers superb all-round visibility with a central elevated position away from the elements with a hard top bimini with sliding roof.
- A 1.2m wide seat / leaning post for seating comfort and standing support.
- Main controls are at the helm making single or short handed sailing easier and safer.
- Steering is direct with the best engineered Jefa systems.
- The head sails are on furlers for ease of deployment and operation.
- Unbelievably stable, near level, comfortable sailing eliminating the exhausting heeling of monohulls and slamming of catamarans.



Rapido 60 #02  
New Zealand

Safety is paramount on the water and the fleet of Rapidos are designed and built to put you in control for fast, safe, fun sailing.

Each Rapido is built to CE-A standard.

- The foam sandwich and carbon construction provides an extremely strong and rigid structure. This rigid structure enables the Rapido to withstand the might of the oceans – without carrying excessive weight.
- Each float (ama) has four watertight bulkheads. The main hull has five bulkheads to ensure that the Rapido is as safe and as unsinkable as possible.
- The engine and main equipment compartment is located under the saloon, protected by two watertight bulkheads.
- The Rapido 53XS (and 50 & 60) has three emergency escape hatches located in the forward cabin, aft cabin and in the main storage compartment under the cockpit.

- The main storage compartment has been specifically designed as a safe survival area.
- Jack stays and clip-on points are provided as are bow and stern carbon cockpit safety rails.
- Automatic and portable bilge pumps are provided.
- The engine compartment has an auto fire extinguisher system. There are three additional portable fire extinguishers and a fire blanket.
- No highly flammable cooking gas with diesel or electric cooking and heating.
- The Rapido is designed for optimal fast performance to get you out of harm's way.
- Power up and away as storm avoidance may be the 'safest option'.

### Escape Hatches and Watertight Bulkheads

- If water ever entered one compartment, the watertight bulkheads will isolate the area and protect the rest of the vessel.
- The Rapido hull and structure are built with foam sandwich construction, combining strength, stiffness, and inherent buoyancy to provide an added margin of safety.

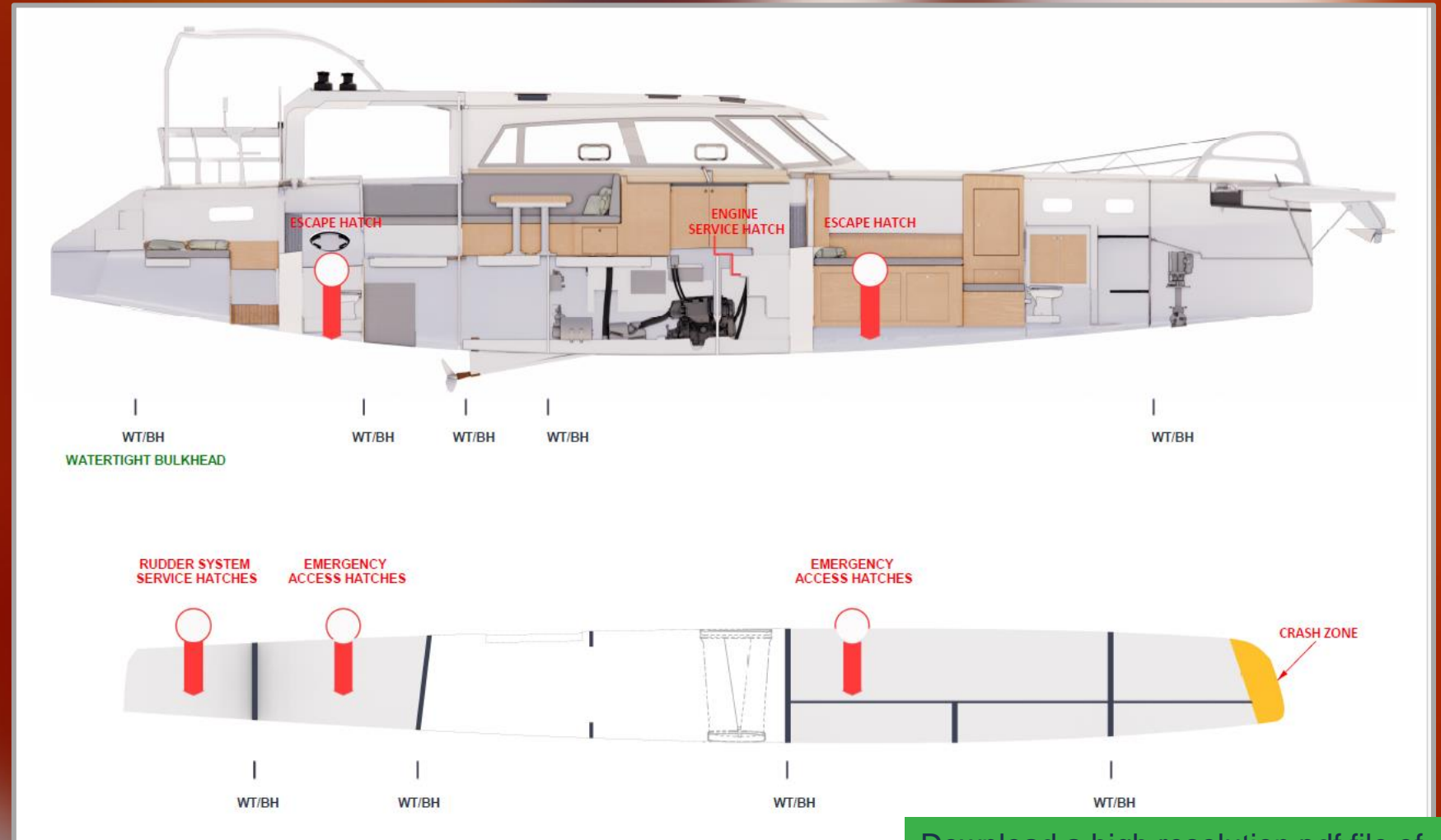

Download a high resolution pdf file of the layout by [clicking here](#).

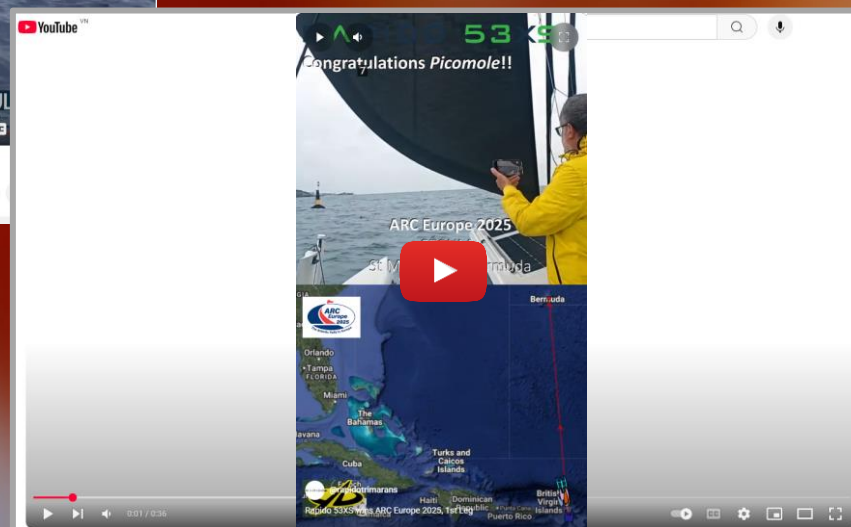
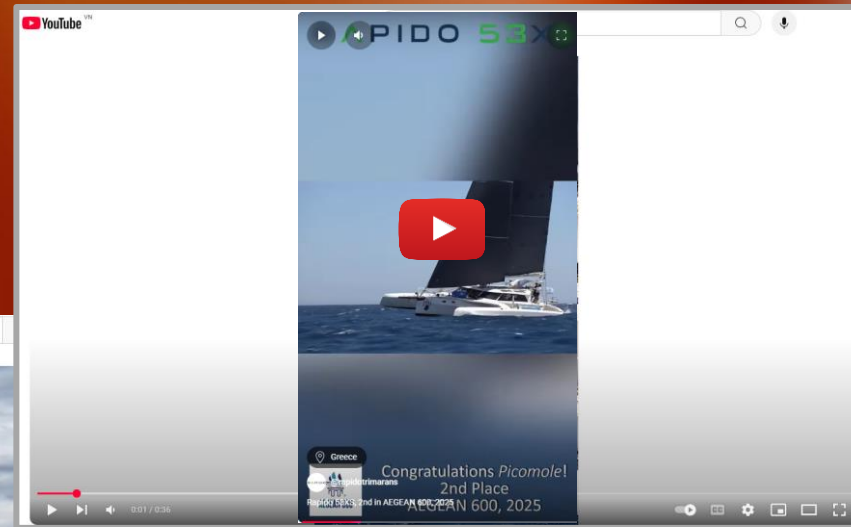
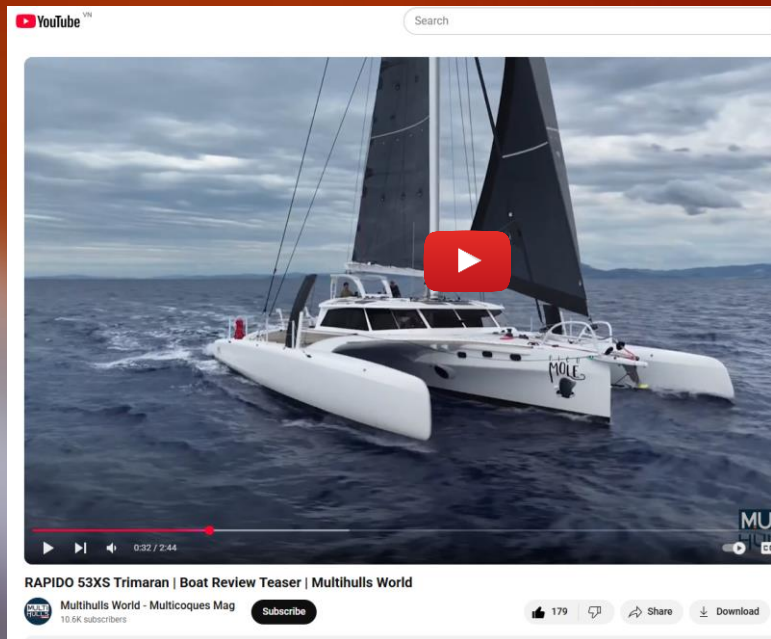

In 2025, Rapido 53XS #01, Picomole has sailed some very successful campaigns:

- Finished 2<sup>nd</sup> in Greece's AEGEAN 600
- Won the 1<sup>st</sup> Leg of the ARC Europe's 870NM stretch from St Maarten to Bermuda. By 230NM (and at one stage, the owner of the boat was cooking an omelette for his crew while the boat sailed at 13 knots. "The boat is starting to perform well", he said afterwards.)

On the surface, sailing can appear to be relaxed and peaceful. And it can be – when you know that underneath and above you sits some of the world's best design and engineering.

Morrelli & Melvin are leaders in their field using the latest technology (eg Computational Fluid Dynamics, Finite Element Analysis and Velocity Prediction Program. [Click here](#)).

Previous M&M projects include the trimaran, BMW Oracle (pictured right) which won the America's Cup in 2010.



### BMW Oracle\*

LOA: 113ft (34m)

LWL: 90ft (27m)

Beam: 89.9ft (27.4m)

Mast height: 180ft (55m)

\*Morrelli & Melvin played a key role on design team.

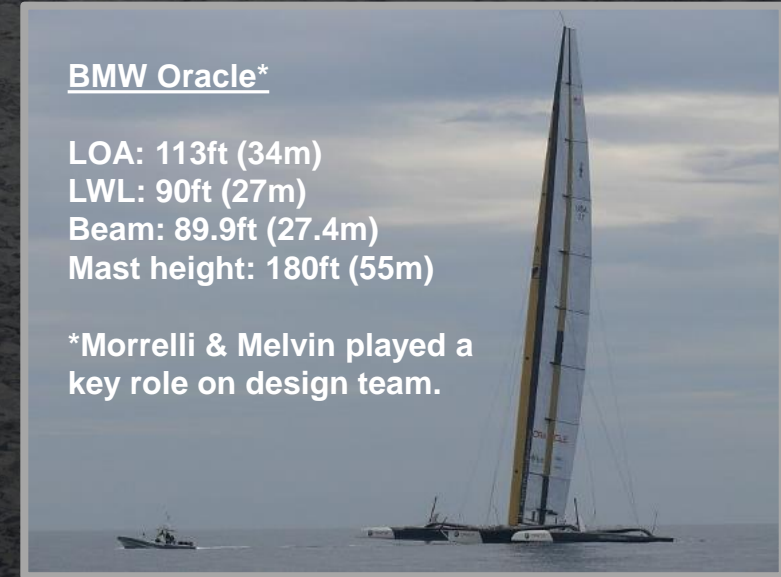

**MORRELLI & MELVIN**  
DESIGN • ENGINEERING • YACHT SALES

# Rapido's Builder: Triac Composites

*"The visit to Triac Composites' factory in Vietnam proved to be amazing, with the size and scope of the boat blowing us away."*

*"With their own autoclave, bake oven, CNC machine, lamination shop, freezers full of pre-preg and a well-planned and managed operation, we were impressed."*

Dougall and Jaz Love  
Owners  
Rapido 60, Romanza



- Triac Composites is located in modern, spacious facilities in Nha Be District, Ho Chi Minh City, Vietnam.
- We are located on the banks of the Nha Be River which gives us the flexibility to launch boats directly into river (or on barge) if required.

# Rapido & Triac Composites

- Parent company (est. 2014)
- Foreign-owned
- Markets and sells Rapido Trimarans  
Hong Kong-based

- Wholly owned by Rapido
- Western senior management and  
production staff
- Shipyard in HCMC
- Builds Rapido Trimarans
- Builds plugs, molds, composite boats,  
parts and products for international  
customers



RAPIDO



TRIIAC  
composites

Exclusive builder:  
Rapidos  
Trimarans

Custom built  
boats / products  
/ parts



- Triac Composites invests in people and technology that enable us to do our own tooling (eg plugs and molds) for production or one-off builds.
- Equipment includes: autoclave (pressurized oven), 7-axis milling robot, CNC Machine and clean room.

## Capability (cont.)



- The Kuka robot mills a plug for the coach roof of a Rapido 50.
- Infusing the all-carbon centre hull for a Rapido 50.

# Rapido Trimarans built by Triac



Rapido 60 (18.3m)

Rapido 50 (15.2m)



Rapido 53XS (16.1m)



Rapido 40 (12.2m)

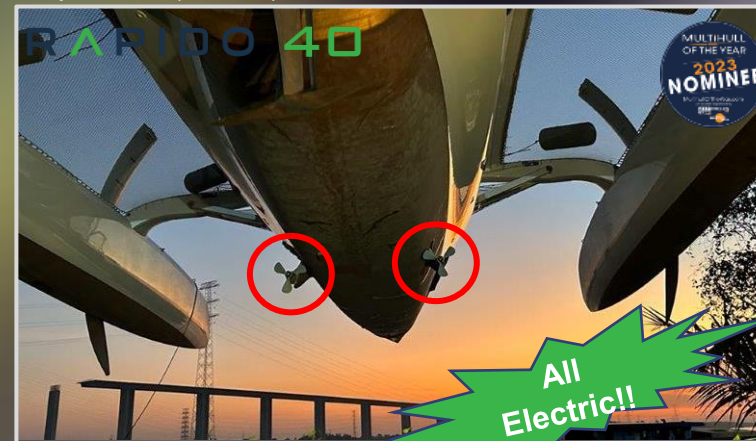

Triac Composites is the exclusive builder of the Rapido Trimarans' fleet.  
NEW! All electric motor now available.

Rapido's trimarans are engineered and designed by world-acclaimed naval architects (eg America's Cup fame) in the USA, Morrelli & Melvin.

## High Tech parts by Triac



- All carbon fibre and composite parts for all Rapido Trimarans (ie, R40, R50, R53XS and R60) are built by Triac
- Highly specialized, high load, carbon fibre parts - made from prepreg and cured in the autoclave - include:
  - Mast
  - Boom
  - Daggerfoils ("C" foils)
  - Rudderblade
  - Beams
  - Bowsprit; and
  - Bulkheads.
- All tooling is done by Triac

Even the drawers are made from prepreg carbon fibre.



# Outsourcing by Triac

Carbon teak table for  
Triac's boardroom.



Triac has built plugs and moulds for international boat builders in the US and Asia.

# Other composite products



Composite interiors for trains: wash rooms, walls, bunks, tables etc



Carbon ventilation tubes for mines and tunnels.



Superstructures for 3 x 24m Danish ferries.



Carbon teak table for Triac's boardroom.

Composite building facades (4m x 2m)



High performance foils for maxi yachts.

# RAPIDO



Paul Koch  
General Director  
Ph +84 939 040 201 (WhatsApp)  
Email: paul@TriacComposites.com

Phil Johns  
General Manager  
Ph +84 773 707 615 (WhatsApp)  
Email: phil@TriacComposites.com



Triac Composites Company Limited  
Factory No. 4, 9 Nguyen Van Tao Street  
Long Thoi Commune  
Nha Be District  
HCMC, Vietnam

[www.rapidotrimarans.com](http://www.rapidotrimarans.com) | [www.TriacComposites.com](http://www.TriacComposites.com)